

# ***Synchronous Generators***

## ***Empowering the Future***

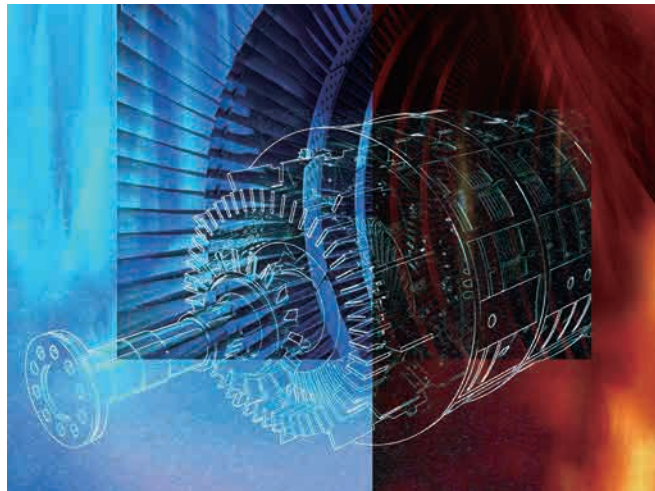

# Continuing the Legacy of Industry-leading Technologies— TMEIC

Combining the manufacturing expertise and marketing experience of parent companies Toshiba and Mitsubishi Electric, TMEIC synchronous generators are designed and built based on more than 200 years of success in heavy machinery production. Today, they are a preferred product of choice for industrial applications. Why is that? One word: Reliability! In keeping with this ever-growing reputation, after careful analysis of customer feedback and industrial trends, we now produce a lineup of generators that can be customized to meet specific requirements. These standardized 2- and 4-pole turbine generators can be tailored to meet diversified needs and provide a best-match solution for virtually any industrial application.

In addition to developing a variety of world-renowned technologies based on our electrical and mechanical engineering experience, we've also introduced a simple structural design and modular generator powertrain complete with a power management system. And you'll find that our generators are fully compliant with relevant international standards too. These features have received high evaluations in the market, and contribute to our generators standing out among the competition in terms of reliability, nonstop performance, low vibration realizing quiet operation and low maintenance requirements/cost.

Whether you are looking for a 2-pole unit or 4-pole unit, TMEIC has a generator that matches your needs.

*Specification flexibility ensures a best-match solution for virtually any application*

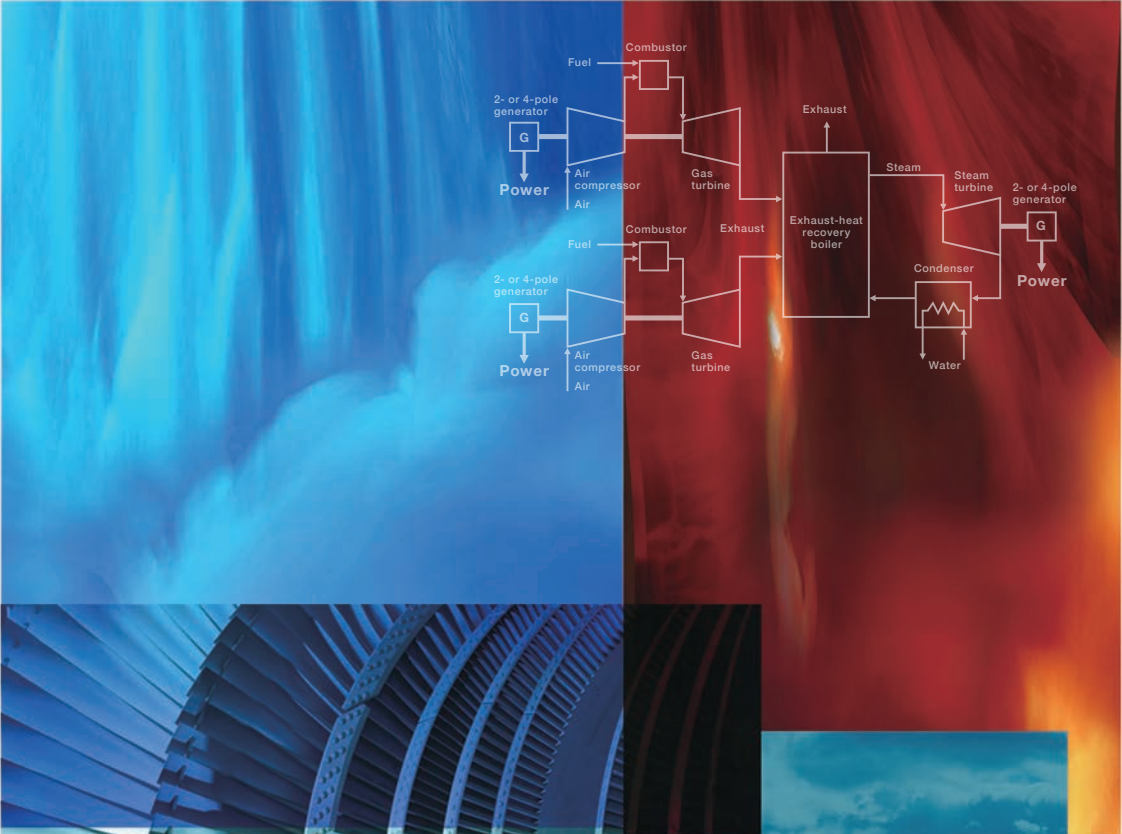

**TMEIC**

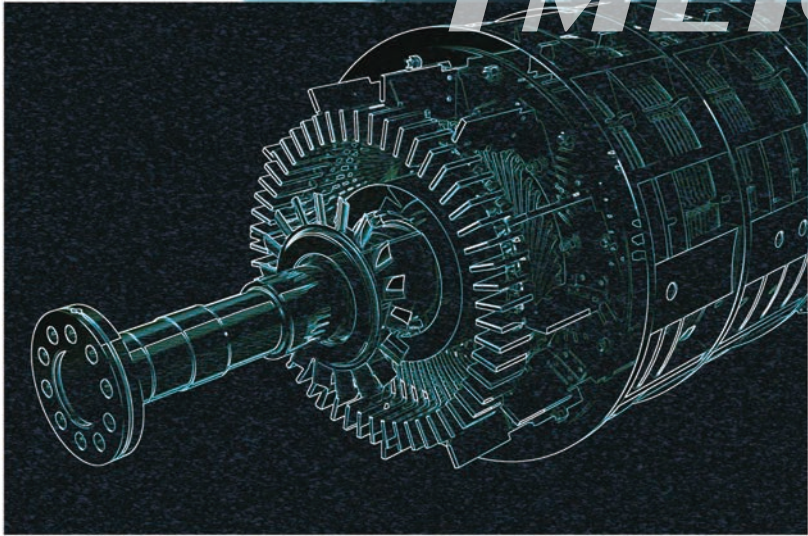

# Generators Customized to Match Local Requirements and Operating Environment

## Multiple Industry Applications – Reliable Nonstop Operation Worldwide

Built using advanced coil processing, VPI treatment, brushless exciters and other cutting-edge technologies, TMEIC generators are renowned for their reliability, superior performance and long service life. Our products are supporting various industries in regions around the world.

### Industrial-use (in-house power generation)

#### Oil and Gas



Leveraging our overall strength as a leading company in motor and drive systems for the industry, from power generation to applications, we offer fully integrated solutions in all areas including offshore plants.

#### Pulp and Paper



Energy-saving power generation based on reusing surplus steam at paper mills and woody biomass power generation, is contributing to the realization of a low-carbon, resource recycling-oriented society.

#### Metals



Generating power utilizing the surplus gas at steelworks to drive equipment such as top pressure recovery turbine (TRT) and coke dry-quenching (CDQ) co-generation systems, we're contributing to energy-saving environmental management.

### Independent Power Production (IPP)



Our broad support of dispersed power systems contributes to the construction of electrical power infrastructures.

### Biomass Power Generation



We supply generators compatible with the turbines in power generation plants that utilize energy produced from the organic activity of plants and other living organisms. In doing so, we're contributing to the realization of an environment-friendly, low-carbon, resource recycling-oriented society.

### Geothermal Power Generation



We provide the generators used in the hydrogen-sulfide gas atmosphere unique to geothermal power generation plants, and are thereby contributing to the realization of an environment-friendly, low-carbon, resource recycling-oriented society.



## Combined Cycle Systems – Pioneering more efficient energy generation

Combined cycle systems bring together gas turbine generator equipment and steam turbine generator equipment in a configuration that results in more efficient energy generation. The high-temperature gas that was previously exhausted as waste from the gas turbine is channeled to an exhaust-heat recovery boiler, where it is efficiently used to heat water. The steam created in the process is then used to drive a steam turbine generator and produce electricity. TMEIC turbine generators are ideal for these co-generation facilities, which offer greatly improved overall energy generation efficiency.

Compared to the high cost and long construction time associated with building thermal power plants, combined cycle generators are less expensive, can be built in a short period of time and are more environment-friendly. As industrial activity increases around the world, we are working to spread the use of our highly efficient combined cycle power generation systems.

### Combined Cycle Generator

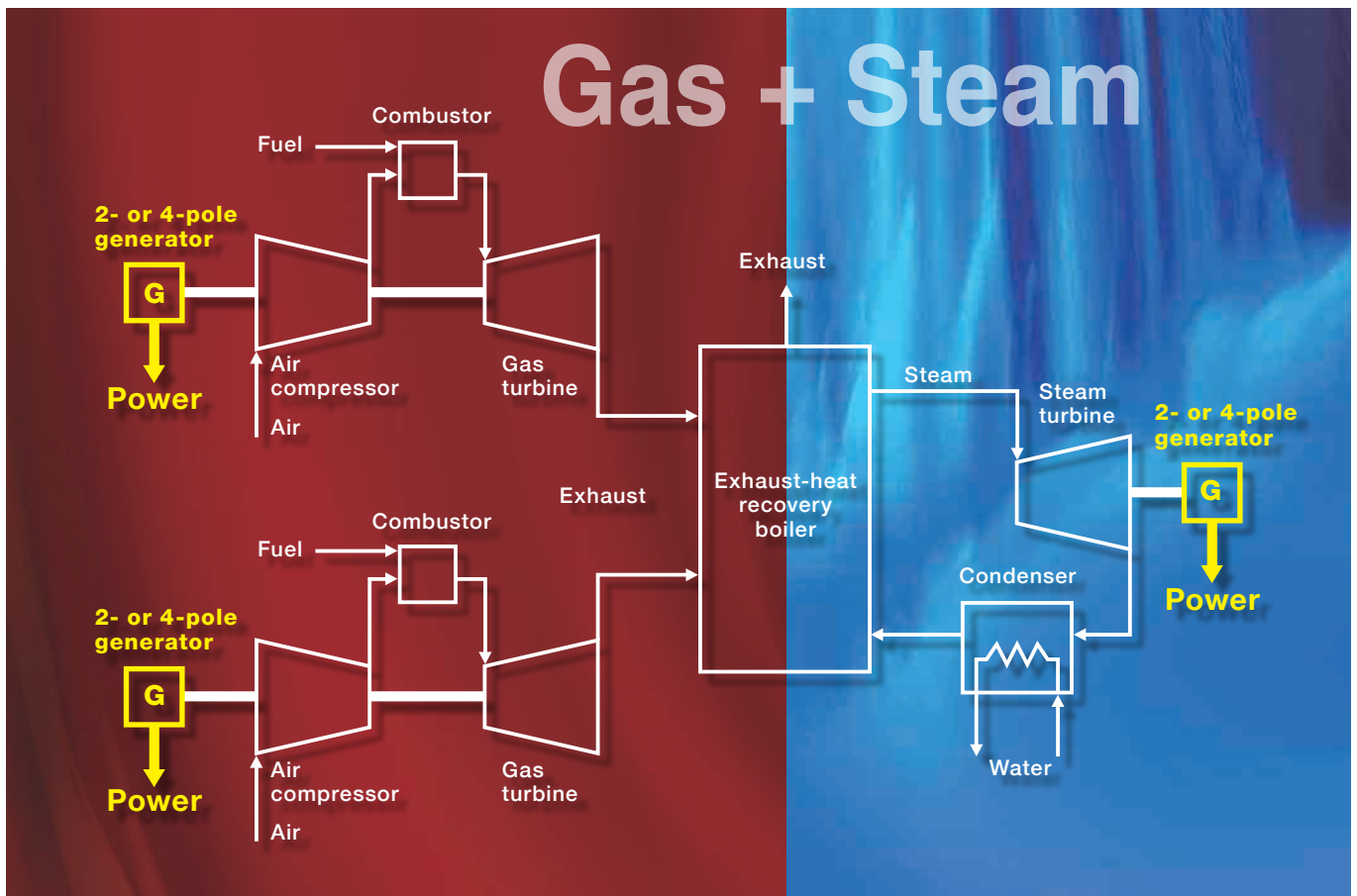

# Large-capacity, Low-vibration, High-efficiency **2-pole** Generators

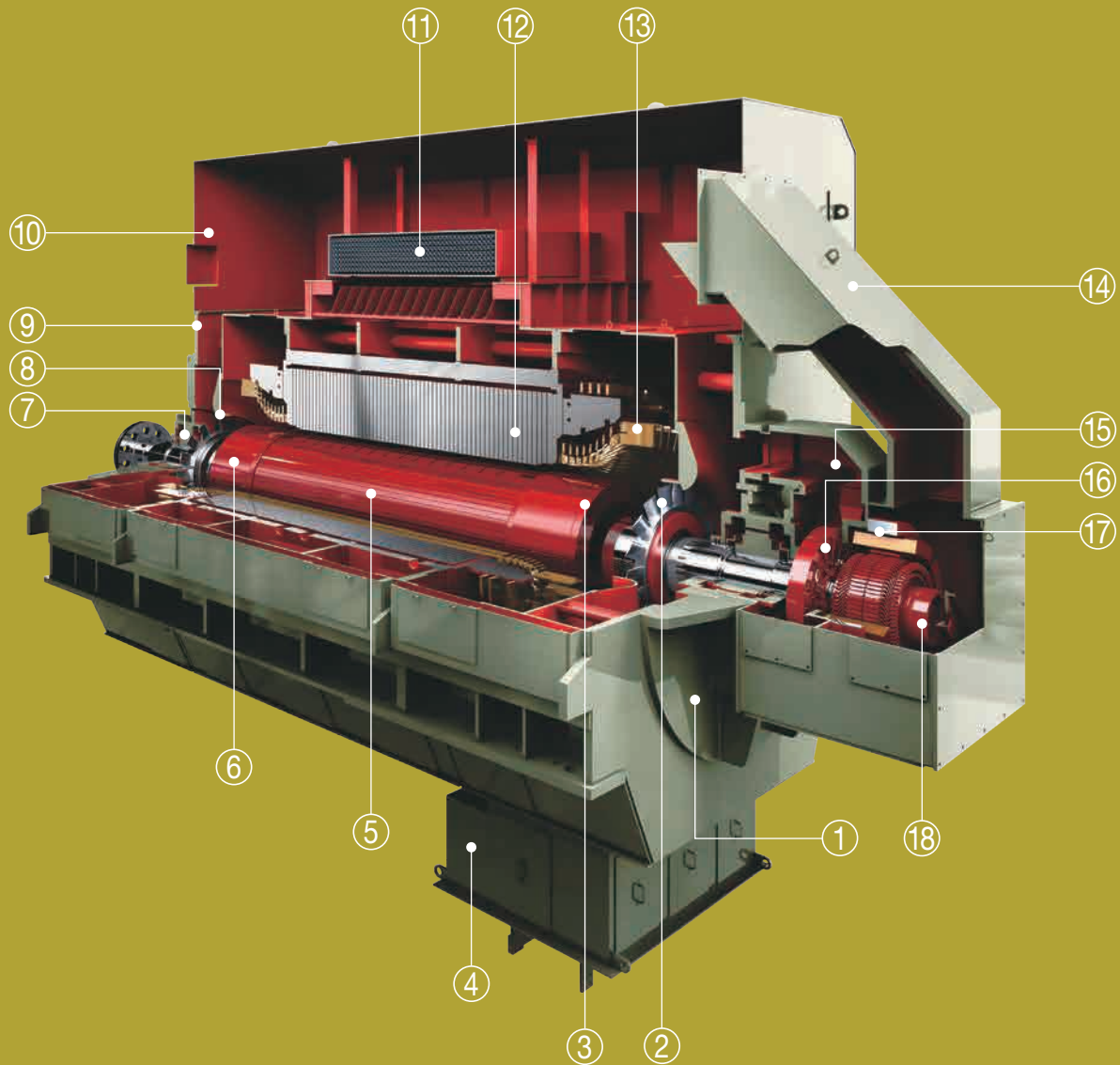

- |                     |                     |                           |
|---------------------|---------------------|---------------------------|
| ① Bracket           | ⑦ Insulated bearing | ⑬ Stator coil             |
| ② Fan               | ⑧ Fan guide         | ⑭ Exciter inlet-air duct  |
| ③ End plate         | ⑨ Frame             | ⑮ Exciter outlet-air duct |
| ④ Main terminal box | ⑩ Air cooler cover  | ⑯ Rotary rectifier        |
| ⑤ Rotor shaft       | ⑪ Air cooler        | ⑰ AC exciter              |
| ⑥ Retaining ring    | ⑫ Stator core       | ⑱ PMG                     |

TMEIC 2-pole generators can be customized to match customer specifications and regional/international standards, thereby realizing a shorter order-to-delivery period. Available in a wide range of capacities as well, they can be combined with steam and/or gas turbines, enabling them to be used for virtually anything.

A special low-loss structural design and rotor shaft made of an advanced steel-alloy that withstands large centrifugal force are just two of the many technologies that contribute to the exceptional low-loss and low-vibration characteristics of our generators, and result in their highly efficient operation.

# High Performance & Long Service Life

## Original advanced technologies throughout

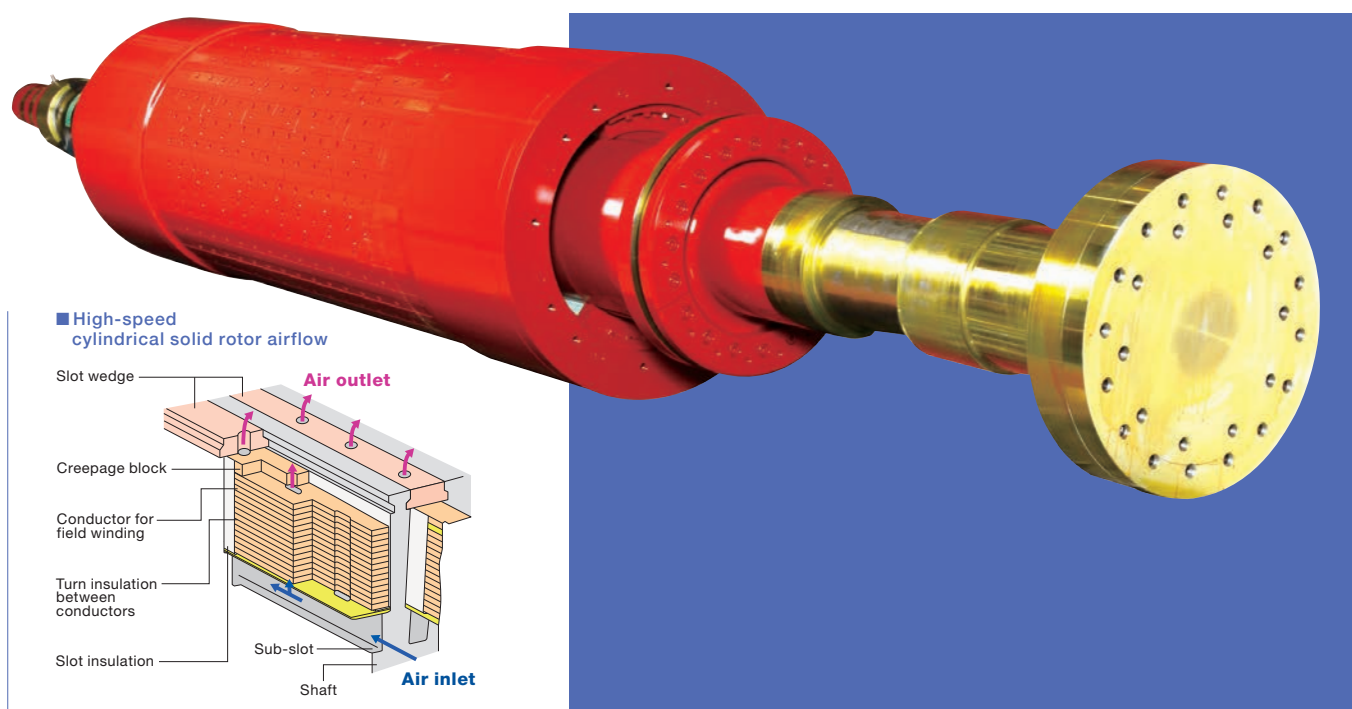

### High-speed, cylindrical solid rotors (2-pole)

The first step in manufacturing this rotor is selection of special steel-alloy materials for the 2-pole rotor shaft that are able to withstand large centrifugal force. After machining, the materials are inspected using ultrasonic flaw detection and rotor balancing tests. This is a key factor in the manufacture of two-pole machines as it provides quality assurance of the materials and the manufacturing process. The rotor coil end is then secured using a shrink-fitted retaining ring, which is made of non-magnetic 18Mn-18Cr steel for large-capacity generators. Before final assembly, the rotor undergoes a high-speed balancing test. Cross-shaped slots engraved at the Y-axis equalize the stiffness at the X and Y axes to achieve highly balanced characteristics, and in turn, low vibration. To cool the rotor and rotor coils, cooling-air is passed through airflow ducts cut under the rotor slots and through holes cut in the rotor coils. The airflow path is optimized to create a constant, efficient cooling-air flow void of inconsistencies to ensure that a low rotor temperature is maintained.

**Low Vibration** – After completing the rotor, high-speed balancing (up to 120% overspeed) and optimal balancing adjustments are carried out to achieve minimal shaft vibration. An optimal bearing and bracket structure developed in-house and a bearing stand with a low vibration value are incorporated, ensuring an overall vibration value compliant with API 546.

**Low Installation Cost** – As the result of adopting bracket-type bearings and a cooler unit with high rigidity for all classes, suspension beams are not needed and integrated support is possible. The exciter can be set directly on the base leaving the overhang as it is. These and other features contribute to reducing installation time and cost.

**Special Specifications** – Explosion protection, API standards and CE mark are all available options for 2-pole generators.

**Optional Instrumentation** – A variety of instruments that have been proven in the market are available, such as vibration indicator, thermoscope and partial discharge monitoring systems.

### 2-pole high-voltage turbine generator

Capacity	Up to 100MVA class
Speed	3,000/3,600rpm
Voltage	11/13.8/15kV
Applicable type of protection	Ex p
Standards compliance	IEC, NEMA, CSA, GOST, CQST, CCOE, API, ABS and others
Cooling method	IC81W TEWAC [option: IC616 TEAAC]
Rotor construction	Cylindrical solid pole
Applications	Steam turbine, Gas turbine

# Highly Reliable, Low-maintenance 4-pole Generators

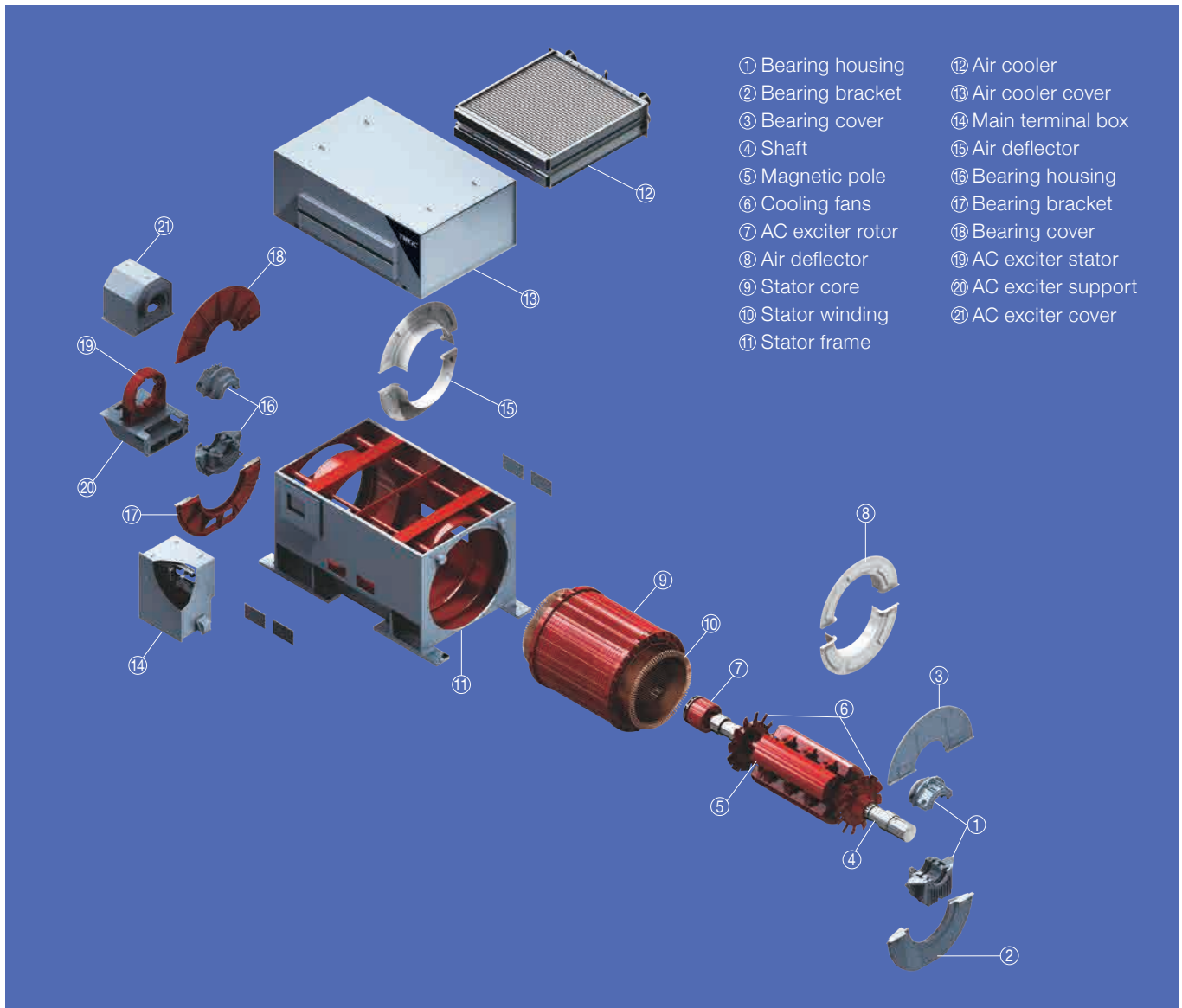

- ① Bearing housing
- ② Bearing bracket
- ③ Bearing cover
- ④ Shaft
- ⑤ Magnetic pole
- ⑥ Cooling fans
- ⑦ AC exciter rotor
- ⑧ Air deflector
- ⑨ Stator core
- ⑩ Stator winding
- ⑪ Stator frame
- ⑫ Air cooler
- ⑬ Air cooler cover
- ⑭ Main terminal box
- ⑮ Air deflector
- ⑯ Bearing housing
- ⑰ Bearing bracket
- ⑱ Bearing cover
- ⑲ AC exciter stator
- ⑳ AC exciter support
- ㉑ AC exciter cover

TMEIC 4-pole generators utilized in combination with steam or gas turbines equipped with reduction gears ensure highly reliable operation and optimum cost performance.

**High Reliability** – When it comes to quality, cutting-edge technological prowess such as the application of our global vacuum pressure impregnation (VPI) treatment enables us to ensure highly reliable performance that supports stable operations at customers’ facilities. Rotor construction includes the use of robust, solid salient poles that contribute to achieving a longer service life: the rotor shaft and pole bodies are integrated, thereby increasing shaft rigidity and enhancing reliability up to overspeed.

**Low Maintenance** – TMEIC’s standard design also minimizes generator maintenance. TMEIC excitation systems incorporate a brushless exciter eliminating brush maintenance. Standard sleeve bearings include a floating labyrinth seal to eliminate oil leakage.

**High Flexibility** – In addition to totally enclosed water-to-air cooling (TEWAC) systems, TMEIC has totally enclosed air-to-air cooling (TEAAC) systems for sites where securing cooling water is difficult. As a result, it’s possible to ensure our systems meet customer specifications and are compliant with national and international standards. Regardless of the desired characteristics, be it efficiency, power factor, short-circuit ratio, impedance or some other factors, we have the flexibility to respond to your needs. This type of flexibility enables us to control schedules efficiently and realize shorter delivery times.

**Easy to Transport** – TMEIC bracket-type generators can be shipped as a single unit, greatly simplifying handling during transportation.



# Designed to Last – Inside and Out

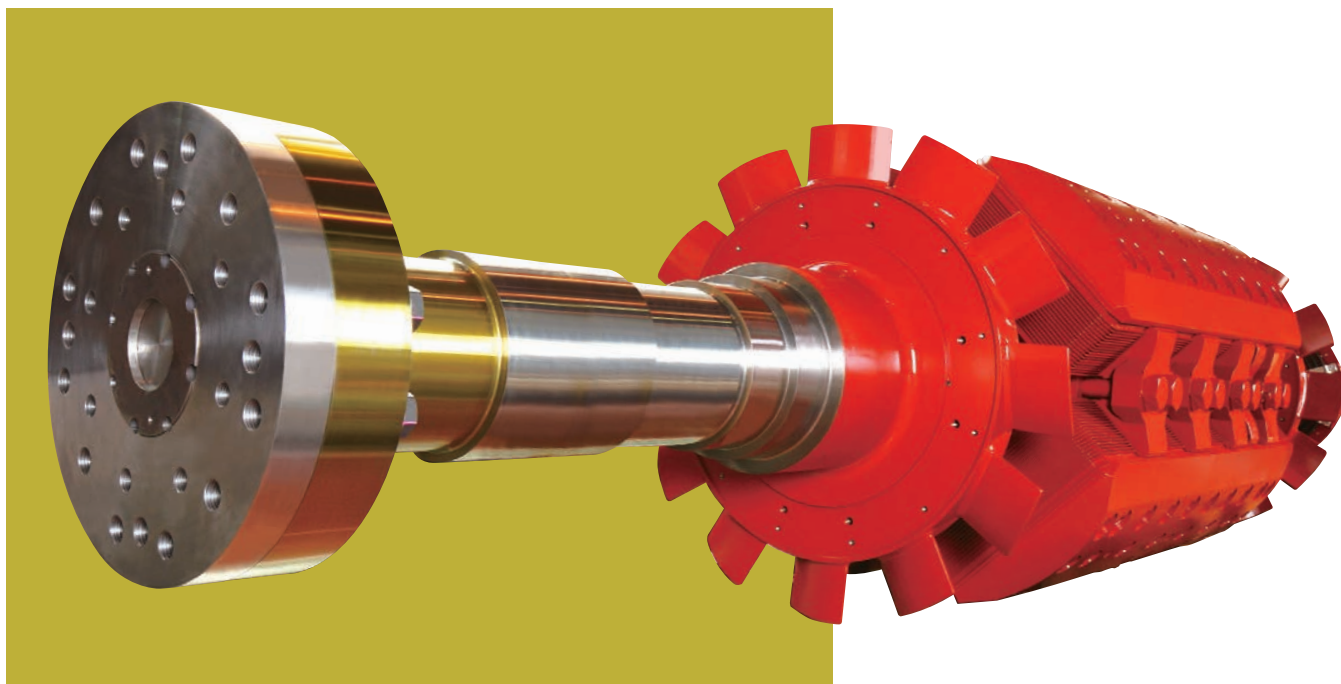

## Salient solid rotors (4-pole)

TMEIC's 4-pole salient pole rotor forms shaft and rotor poles from a single steel forging. Robotically welded copper field coils are fitted over these poles. The field coils are firmly held with spring-loaded retainers, eliminating the need for re-tightening pole bolts through the life of the machine. A pole tip is bolted to each pole to form a maintenance free, integrated assembly. The large coil and pole design's large cooling-surface area and efficient cooling-air flow maintain the rotor at a uniform low temperature. The rigid rotor structure of TMEIC's 4-pole design optimizes the distance between the bearings to move the first critical rotor speed to 120% or more of the rated speed to minimize vibration. Furthermore, owing to the flexible construction of the rotor coil connector, the generation of mechanical and heat stress in the structure is prevented.

## Reduction speed

The option of placing a reduction gear between the turbine and generator is provided for the 4-pole generator lineup. Optimal operating conditions can be selected for systems equipped with the reduction gear.

## Global Standard Compatibility

TMEIC generators can be customized to the specifications and requirements of virtually any region. Products are therefore compliant with global standards such as NEMA and IEC, regional standards like IECs<sub>x</sub>, CSA, GOST, CQST and CCOE, and industry explosion-protection standards (Ex ec and Ex p). It is also possible to accommodate special requests for API and ABS specifications.

## ■ 4-pole high-voltage turbine generator

Capacity	Up to 70MVA class
Speed	1,500/1,800rpm
Voltage	6.6 to 13.8kV
Applicable type of protection	Ex ec, Ex p
Standards compliance	IEC, NEMA, CSA, GOST, CQST, CCOE, API, ABS and others
Cooling method	IC81W TEWAC [option: IC616 TEAAC]
Rotor construction	Salient solid pole
Applications	Steam turbine, Gas turbine

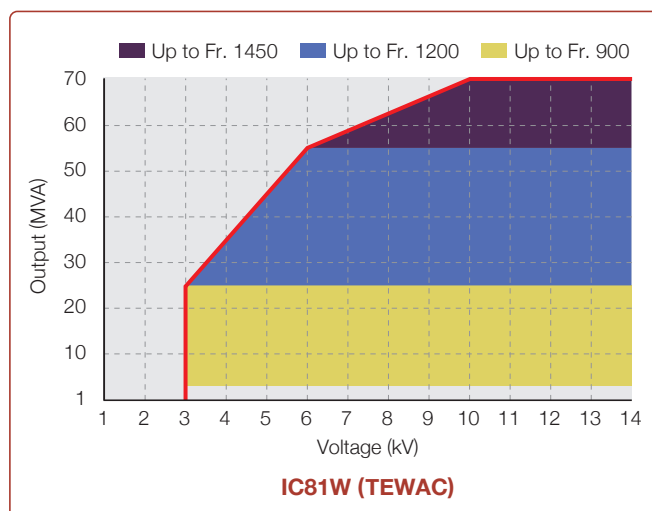

# Optimized Components and Structural Design

Stator

Structure optimized for high efficiency



The stator core structure consists of electromagnetic steel sheets that are first laminated and then pressed using stud and end-plate bolt connections. The electromagnetic steel sheets are produced using high-quality, thin-plate silicon steel low in iron-loss and with insulation coating on both sides. The stator core, which contributes to high motor efficiency, has an air duct built into it. The air duct dimensions and its position contribute to realizing the best possible cooling efficiency, and ensure uniform heat distribution throughout the stator coil.

Using techniques such as the finite element method (FEM), modal analysis is conducted to accurately understand the natural vibration mode; information that is then utilized to eliminate vibration due to resonance.

Frame

High rigidity suppresses vibration

The stator frame is produced utilizing a combination of press processing and welding, realizing a compact, highly rigid structure. The rigid structure restricts vibration to a minimum by transferring all the excitation force applied to the stator through the frame to the base. Horizontal, inclined or vertical mounting is possible.



## Bearings

## Supporting smooth, reliable operation

The type of bearing system used is determined by operating conditions such as the application, radial and axial loads, impact load, revolutions per minute, ambient temperature, and other factors such as vibration level, coupling method and customer preferences. Brackets are adopted as standard for bearing support, and in the case of large machines, pedestal bearings are used. Standard sliding bearings have a two-part structure with the outer circumference cast in white metal. Maintenance and inspections are simplified as there is no need to remove the machine-side couplings. The bearings are insulated to protect the bearing metal from the shaft current. A grounding brush and copper belts are used to ground the shaft. A forced-feed oil supply system is required. If very low operating speeds will be used, a jacking oil pump may be necessary.

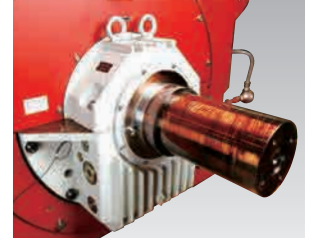

## AC Exciter

## Brushless exciter system

TMEIC's standard excitation is a DC brushless excitation system. The system consists of a rotating AC exciter winding, a shaft mounted rectifier and PMG permanent magnet generator.

The plant excitation regulator systems provide low-current DC to the stationary DC field winding. The AC exciter's three-phase revolving armature field generates variable voltage AC power that is fed to the rotary rectifier circuit firmly mounted to the shaft. The DC voltage from the rectifier energizes the main DC field to control power output of the main generator.

The PMG provides an optional alternate source of AC power to the plant excitation regulator system. This alternate excitation power is supplied from the PMG as the generator spins. If an AC fault or short-circuit occurs, dropping out the normal AC source to the generator field regulator, the alternate source from the PMG can maintain the generator field current. This also provides a separate excitation source at the generator startup time.

The design margin of the rectifier diodes gives reliable operation under the most severe generator operation. These highly reliable diodes are configured as shown in six arms (2 pole machine, 2S-3P-6A with series-parallel redundant rectifiers; and 4 pole machine, 1S-1P-6A). The discharge resistor shown protects the diodes and field from overvoltage voltage surges.

No carbon brushes or collector rings are used resulting in continuous operation with minimal maintenance and easy servicing

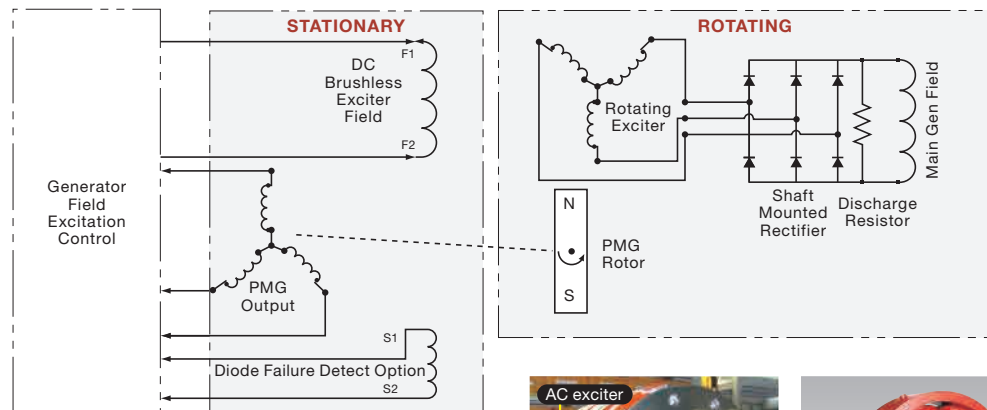

The brushless exciter and PMG wrap around the generator shaft, so additional bearings are not required. There is no collector ring nor carbon brush, so no carbon dust. As a result, daily inspections aren't required.

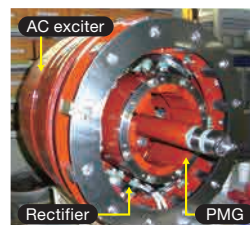



# Superior Reliability through Precise Insulation

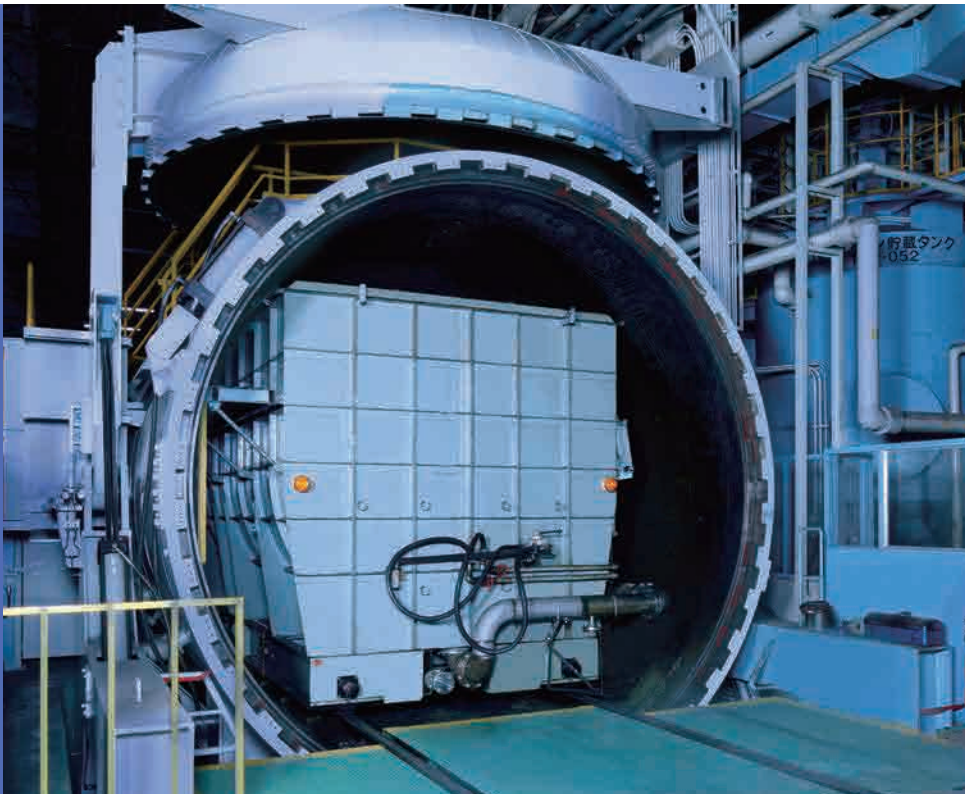

## Vacuum-pressure impregnation for systems up to 250MW– Built on refined technologies and a record of success

As standard, the entire core and windings of TMEIC generators undergo vacuum-pressure impregnation (VPI) using epoxy resin. The TMEIC VPI treatment subjects the whole winding to impregnation simultaneously so as to provide a continuous, strong and highly reliable insulation structure free of even minute weak points. In addition to outstanding insulation performance, the excellent heat conductivity of the winding provides a powerful cooling effect. These features are the foundation of additional benefits for the customer, such as class-F heat resistance, excellent surge withstand capacity, high resistance to severe environmental conditions, strong, durable mechanical characteristics, and consistent insulation characteristics.



### Example of insulation construction

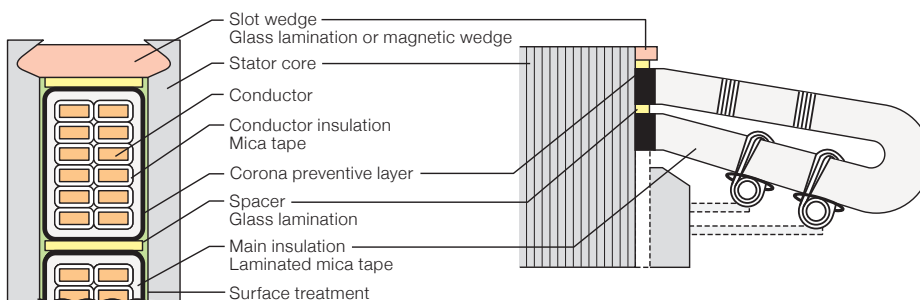

The insulation class and specifications are designed to ensure highly reliable insulation. Mica tape is used to prevent corona discharge effects, and there is a special area for conductive corona protection.



# Efficient, Effective Cooling

TMEIC generators are specially designed for high performance, which requires that they are efficiently and effectively cooled during operation. Depending on the type of generator, there are three cooling methods to choose from: water-to-air, air-to-air or pipe-ventilated. We will help you choose the one that best matches your needs.

## Totally enclosed water-to-air-cooled (TEWAC)

Figure

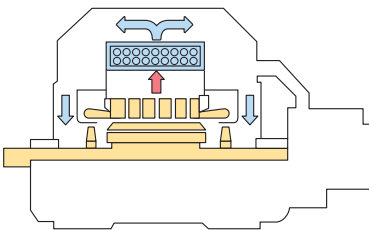

Degree of protection: IP54 (option: IP55)

Cooling method: IC81W

Utilities required: Cooling water

### Cooling path

Cooling air circulates in a path closed off to the outside through the heat source inside the generator and the water-cooled heat exchanger

### Features

Good cooling performance; environmental resistance; most compact and cost-effective solution for large-capacity generators for sites with supply of cooling water; noise can be restricted to low levels

## Totally enclosed air-to-air-cooled with fan (TEAAC with fan)

Figure

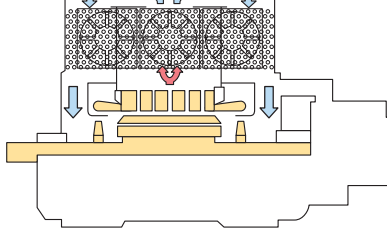

Degree of protection: IP54 (option: IP55)

Cooling method: IC616

Utilities required: Power-supply for fan

### Cooling path

A fan is used to create a forced flow of cooling air from the outside, which then circulates in a path closed off to the outside through the heat source inside the generator and the air-to-air heat exchanger.

### Features

Bigger than TEWAC in terms of external dimensions but can be used at sites where there is no cooling water supply. Installation of a fan further enhances cooling performance and enables a larger capacity.

## Totally enclosed pipe-ventilated (TEPV)

Figure

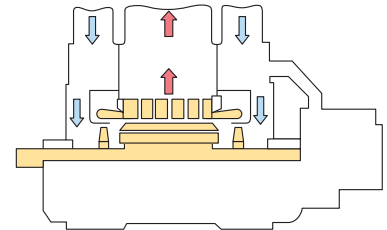

Degree of protection: IP54 (option: IP55)

Cooling method: IC97

Utilities required: Cooling air

### Cooling path

Cooling air supplied from the outside circulates in a path closed off to the outside through the heat source inside the generator and the heat exchanger, located at a distance, through a duct

### Features

Most compact, cost-effective solution for sites with a supply of cooling air but without a supply of cooling water

## Ready to respond to all system needs

The schematic diagram on the right shows an example of a typical electrical system required for generator management, including protection, excitation and intermediate voltage panels. TMEIC supplies this full scope of products, and is ready to resolve your system needs.

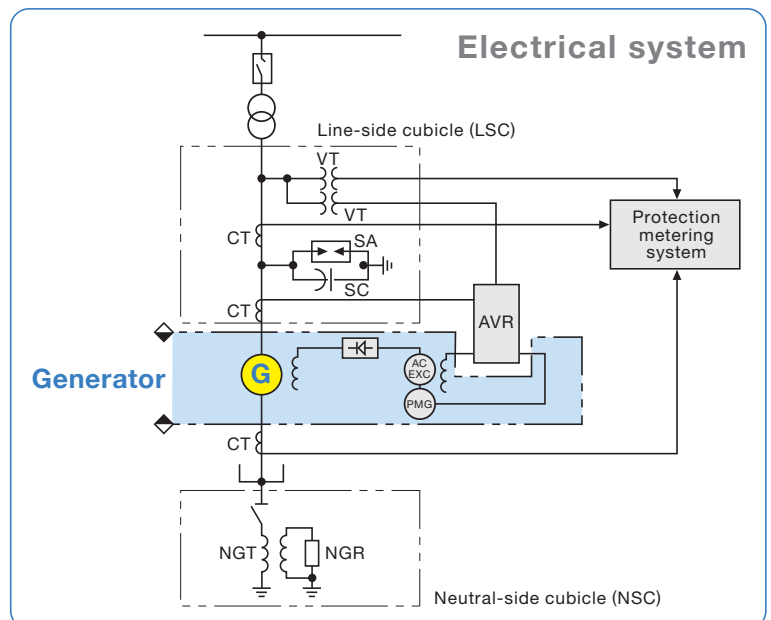

# Standard or Custom Specifications – Built to your requirements

Item		2-pole generators	4-pole generators	Options
Rating	Rated output	5,000–100,000kVA (approx.)	5,000–70,000kVA (approx.)	
	Rated voltage	11/13.8/15kV	6.6 to 13.8kV	Customer specifications (3 to 6kV for 4-pole)
	Frequency	50Hz or 60Hz		
	Poles	2	4	
	Rated speed	3,000rpm or 3,600rpm	1,500rpm or 1,800rpm	
	Rated power factor	85% lagging	80%–90% lagging	Customer specifications
Enclosed		Totally Enclosed Water-to-Air-Cooled (TEWAC)		Totally Enclosed Air-to-Air-Cooled (TEAAC) Totally Enclosed Pipe-Ventilated (TEPV)
	Protection	IP54		Customer specifications
	Cooling method	IC8A1W7		Customer specifications
Applicable standard		IEC60034		Customer specifications
Site conditions	Location	Indoor		Outdoor
	Ambient temperature	Max. +40°C Min. –5°C		Customer specifications
	Altitude	Less than 1,000m		Customer specifications
	Humidity	Less than 95%		Customer specifications
	Voltage variation	Less than ±5%		Customer specifications
	Frequency variation	Less than ±2%		Customer specifications
Rotor configuration		Cylindrical rotor	Salient solid pole rotor	
Insulation rating		F-Class insulation		
Temperature rise		B-Class temperature rise		F-Class temperature rise
Excitation system		Brushless excitation (with PMG)		Customer specifications
Direction of rotation		Customer specifications		
Shaft construction	Shaft extension	Single shaft		Customer specifications
	Shaft end geometry	Solid		Customer specifications
Air cooler	Location	Top mount		Customer specifications
	Water inlet temperature	32°C		Customer specifications
	Water supply pressure	0.5MPa (allowable design value)		Customer specifications
	Kind of water	Fresh water		Sea water
	Type of cooling tube	Single tube		Customer specifications
	Tube material	90-10 Cu-Ni	Deoxidized copper	Customer specifications
	Direction of piping flange	Left side (viewed from exciter side)		Right side (viewed from exciter side)
Bearings	Type of bearings	Sleeve bearings (forced lubrication)		
	Oil temperature	45°C		Customer specifications
	Oil pressure	Approx. 0.1MPa		
	Lubricating oil	ISO VG32		Customer specifications
	Direction of piping flange	Left side (viewed from exciter side)		Right side (viewed from exciter side)
Main terminal	Number of terminals	6 (star connection)		Customer specifications
	Terminal box position	Bottom	Right side (viewed from exciter side)	Customer specifications
Painting	Color	Munsell 2.5PB6/2		Customer specifications
	Thickness	50µm or above		Customer specifications
Accessories		1 set – Sole plate		
		1 set – Fixing bolts		
		6 pcs – Stator winding temperature detector RTD		
		2 pcs – Bearing temperature detector RTD		2 pcs – Dial bearing temperature indicators
		2 pcs – Inlet-air temperature detector RTD		
		1 pc – Outlet-air temperature detector RTD		
		1 set – Space heater		
		1 set – Auxiliary terminal box for instrumentation		
		1 pc – Air-cooler water leakage detector		
		1 set – Orifice for lubrication oil inlet		
		1 set – Earth terminal		
		1 set – Special tool		
				1 set – Oil flow viewer
				1 set – Copper belt/carbon brush for grounding shaft
			Others: Customer specifications	

# Independent Power Production – TMEIC offers everything you need



For IPP  
2-pole Air-cooled  
Turbine Generator

In Water-cooled TEWAC Enclosure

2P-58MVA-11kV-60Hz



For IPP  
4-pole Air-cooled  
Turbine Generator

In Water-cooled TEWAC Enclosure

4P-37MVA-11kV-60Hz  
Pressurized Explosion-proof

## Global Standards

TMEIC generators are compliant with all global standards and backed by a worldwide service network ready to support customer needs. Quality, reliability and safety, the concepts on which TMEIC products are built, are the same concepts global standards are based on. The end result is benefits for both customers and the environment. Our generators have received hazardous area certification in most regions around the world.

### Global Protection and Certification

	Europe	Russia	China	Korea	Australia	India	USA	Canada	Brazil	Others
<b>Standard</b>	EN & ATEX	IEC	GB	IEC	IEC	IEC or EN & ATEX	NEC & ISA	CSA	ABNT & IEC	IEC or EN & ATEX
<b>Certification Body</b>	SGS Baseefa	Nanio CCVE	CQST or NEPST	KOSHA or KGS	SGS Baseefa	CCOE	FM or SGS NA	CSA	NCC or LMP	SGS Baseefa

# Global Sales/Manufacturing/Service Network

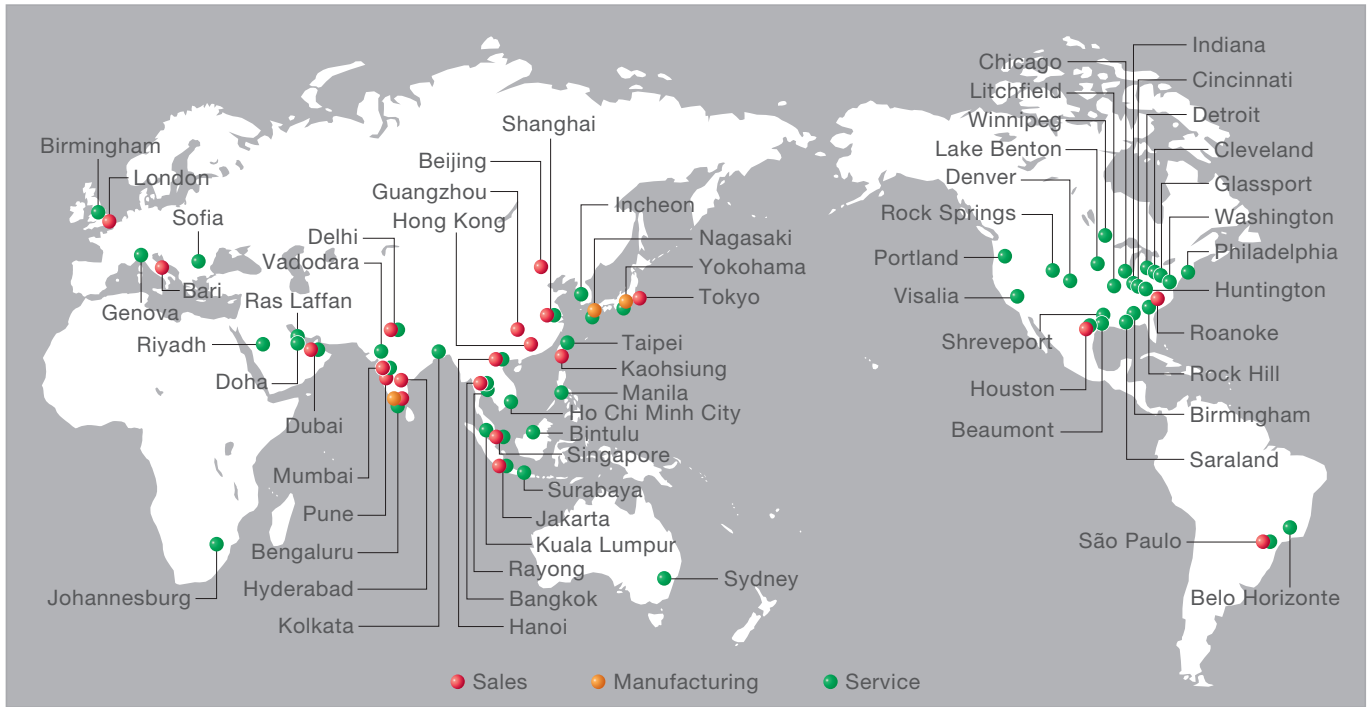

[www.tmeic.com](http://www.tmeic.com)

All specifications in this document are subject to change without notice. This brochure is provided free of charge and without obligation to the reader or TMEIC, and is for the purpose of information only. TMEIC neither accepts nor implies any liability regarding the information provided herein.

©2024 TMEIC Corporation, Japan  
All rights reserved.