

More Compact, Improved Performance

TMEiC
We drive industry

Large-capacity TEFC Motors

Variety of models to match diversified industrial needs

Amazing Efficiency - Enhanced Reliability



High-voltage motors

Introducing an evolutionary change in the structural and casing designs of TMEiC TEFC motors: compact, large-capacity units built for simple installation, easy maintenance and reliable non-stop performance under harsh operating conditions.

1

Fr. 560 Wide-ranging TEFC Motor Lineup

Vast lineup of TEFC motors in various sizes and ratings ensures a best-fit solution to the diversified motor needs in various industries.

- Diversified lineup
- Small frame, large-capacity
- Harsh environment durability

2

State-of-the-Art Heat Ventilation Analysis

Impressive reduction in size realizes space-saving installation and lower shipping cost. As air duct and water cooler are not required, the cost of maintenance is reduced too.

- Space-saving installation
- Transportation/ Shipping cost reduced
- Maintenance cost reduced

3

Designed and Built Using Extensive Experience

Decades of experience are applied in the production process, realizing stator windings and rotor cages of the highest quality.

- Stable, nonstop operation
- Low vibration, long service life
- Clean/Safe work environment
- Low maintenance

Specifications

Rated voltage	Up to 6.9kV
Rated speed	Up to 1,800rpm (Applicable for VVVF drive)
Number of poles	4P, 6P, 8P-
Cooling method	IC411 / IC416
Enclosure	TEFC / IP55, IP56

Shaft height	Up to 560mm
Thermal class	155(F)
Temperature rise limit	80K(R) / 90K(ETD)
Bearings	Antifriction / Sleeve
Standards	IEC, BS, IS, AS, NEMA, JEC, etc...

Designed Considering the Operating Needs of Diversified Applications and Industries



IC411 Sleeve bearing



IC416 Antifriction bearing

World-class High Efficiency

Designed for the production of smaller motors with the same large-capacity performance, cooling efficiency has been improved and heat loss reduced. Additionally, working to ensure stable, low-vibration operation over long periods of time, overall structure and processing/assembly methods were reviewed, and the friction loss from internal parts and bearings has been reduced. These efforts have enabled TMEIC motors to achieve a world-class level of high efficiency that effectively contributes to lowering operating costs.

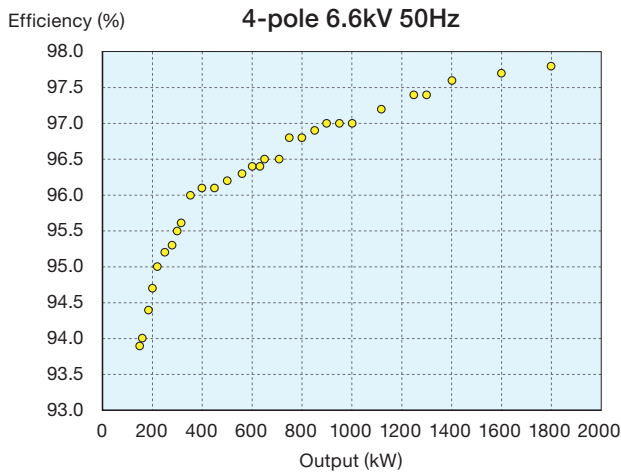

Downsizing through Cutting-edge Technologies

Various measures such as incorporating the latest technologies to improve cooling efficiency have enabled TMEIC to reduce motor size. Compact and lighter, handling during transportation and installation is easier, and the space required for installation is less.

Installation Flexibility

Ample flexibility for connecting the terminal housing is designed in. In addition to top mounting, side mounting is now possible, including the ability to rotate the outlet pitch a full 90-deg.



Superior Waste Grease Removal System

Motor design includes a unique grease extraction system where old, heavy grease drops into a cassette low in the motor casing that can be removed quickly and easily. There is no need to shut down operation, and there is little or no burden on operator or motor.

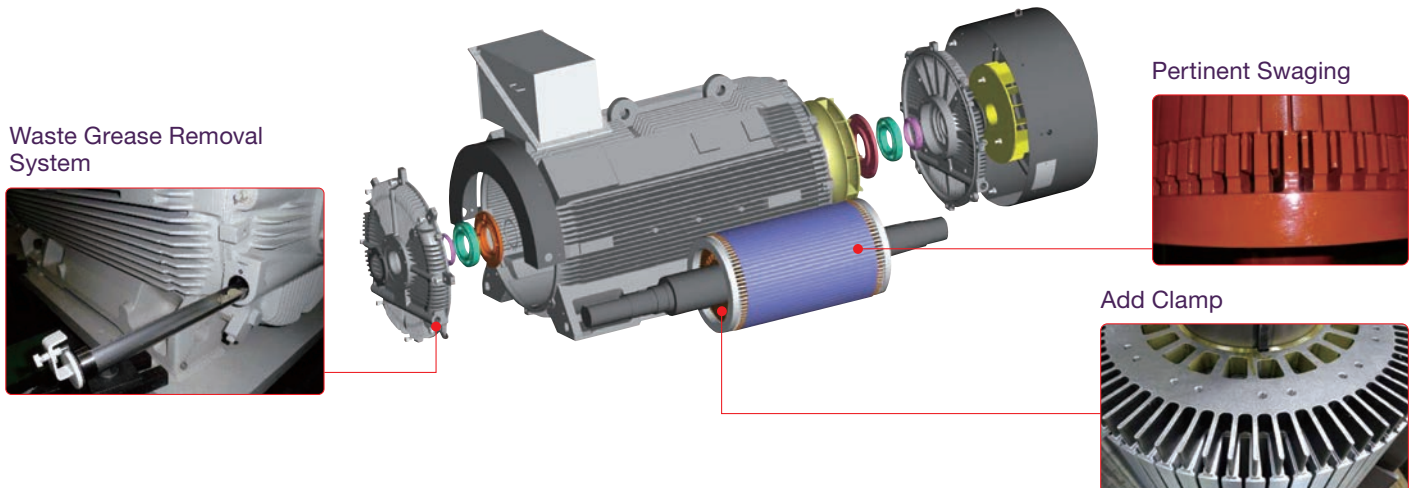

Built for Heavy-duty Operation

Remarkably low vibration has been realized by applying knowledge accumulated in previous successes together with the ongoing analysis and optimization of rotor and stator designs. Other developments include introducing bar swaging along the rotor and thorough improvements in the smallest of details such as optimizing the clamps in the rotor core. Now more durable and robust, TMEIC rotors provide reliable heavy-duty operation for longer periods of time.